



Freeze-Resistant Two-Station Marblyte™

Barrier-Free Fountain

MODEL 7120 FR



This fountain is certified to NSF/ANSI 61.

GENERAL

Two-Station face-mounted fountain made of White Granite Marblyte™ solid-surface non-porous polymer. Contour-formed basin with softly rounded corners and edges reduces splatter, insures proper drainage and prevents standing waste water. Designed to be easily accessible on either side to both physically challenged and able-bodied individuals. Ideally suited for installation in public areas. Model meets state and federal requirements as defined by the Americans with Disabilities Act.

FREEZE-RESISTANT VALVE SYSTEM

Freeze-resistant system features box that installs behind non-freezing wall for housing water connection from the stop to the strainer.

BUBBLERS

Facing vandal-resistant bubblers are one-piece, chrome plated, and are secured to fountain with anti-rotation mounting system. Unit has integral hood guard design to prevent contamination from other users, airborne deposits and tampering.

PUSHBUTTON ACTUATION MECHANISM

Self-closing, vandal-resistant pushbuttons do not require grasping or twisting.

AUTOMATIC STREAM HEIGHT REGULATOR

Self-closing corrosion-resistant stop/regulator is located inside unit to prevent tampering. A constant stream height is automatically maintained under line pressures that vary from 20 to 105 psi.

BOTTOM COVER

Fountain is equipped with a bottom cover. Cover is secured to the fountain with vandal-resistant fasteners.

INLET STRAINER

Easily cleaned in-line strainer screen traps particles of 140 microns or larger before they enter the waterway.

WATER INLET

3/8" O.D. tubing into freeze-resistant box.

DRAIN OUTLET

1-1/4" waste outlet located in freeze-resistant valve system.

SUGGESTED SPECIFICATIONS

Fountain shall include pushbuttons on the front, contour-formed basins to eliminate splashing and standing water, and shall have rounded corners and edges. Projectors shall be chrome-plated vandal-resistant type with integral hood guard and anti-squirt feature. Fountain shall comply with ANSI 117:1 and ADA for visual and motion disabilities. The manufacturer shall certify the unit to meet the requirements of NSF/ANSI 61, and the Safe Drinking Water Act.

Note: Continued product improvement makes specifications subject to change without notice. See Halsey Taylor website for most current spec sheet.



Standard Finish is White Granite Marblyte™

Optional Accessories (extra cost)

Standard Double Bubblers™

Each 7120 FR consists of 2 cartons of the following:

Fountain, Panel and Misc. Parts
Freeze-Resistant Valve System

Service stop not included.

Shipping weight: 85 lbs.

JOB NAME: _____

ENGINEER/CONTRACTOR NAME: _____

APPROVAL: _____
DATE: _____



7120 FR

**Freeze-Resistant
Two Station Marblyte™
Barrier-Free Drinking
Fountain**

(CONTINUED)

MOUNTING INSTRUCTIONS

Refer to diagrams for rough-in of freeze-resistant valve system and plumbing. Bolt fountain securely to wall per installation instructions. Water supply and waste line are to be assembled as required. The final check for leaks and correct functions of fountain should be made. (For details see the installation instructions.)

Freeze resistant box must be installed on interior non-freezing wall.

OPERATING PRESSURES:

Supply water - 105 psi maximum

Important: For required wall support locations see installation instructions provided with fountain.

NOTE: A service supply stop (not included) must be installed at the fountain inlet line.

TOP VIEW

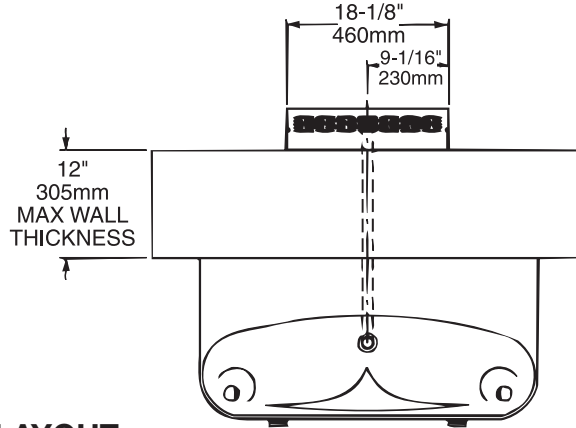

WALL LAYOUT

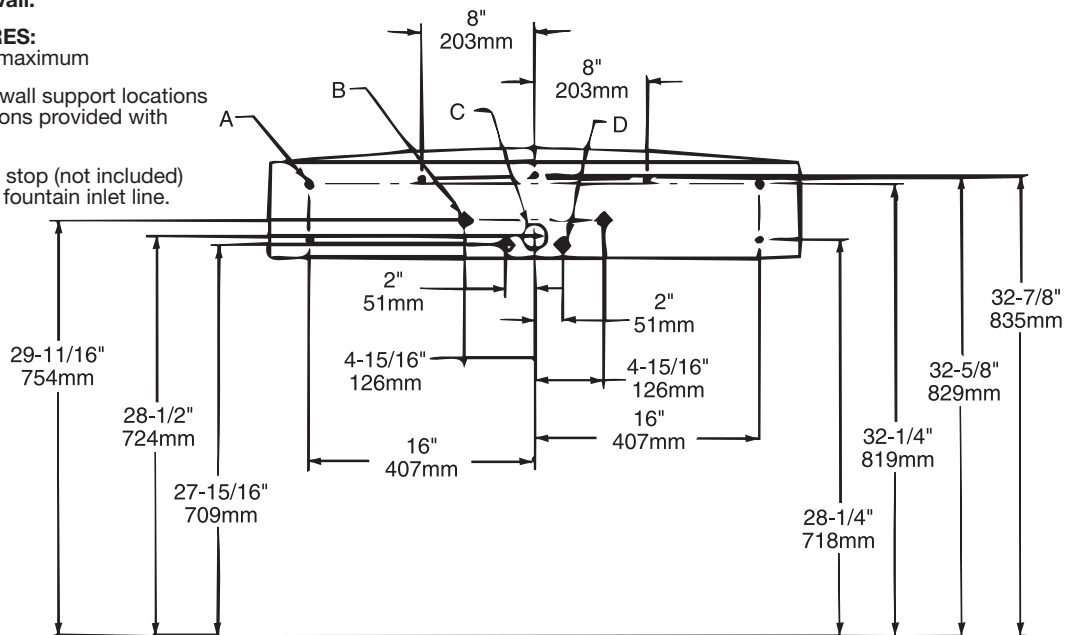

LEGEND:

- A = HOLE LOCATION FOR SECURING FOUNTAIN TO WALL
- B = 7/8" DIA. (22mm) HOLE FOR OPERATING CABLE
- C = 1-3/4" (44mm) HOLE FOR WASTE LINE
- D = 7/8" DIA. (22mm) HOLE FOR WATER SUPPLY TUBE

SIDE VIEW

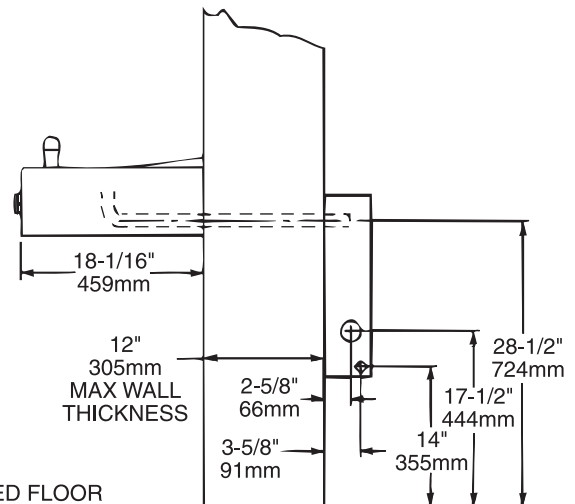

FRONT VIEW

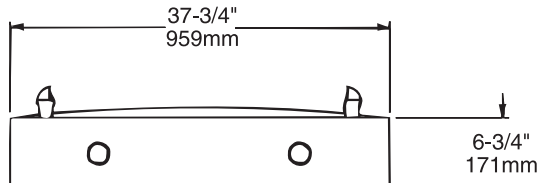

1-1/4" Trap provided.

27"
686mm
ADA
REQUIREMENT

FINISHED FLOOR

Halsey Taylor®